



ARMSTRONG

Armstrong is a collection of timeless, robust armchairs, armbenches, and tables designed for semi-public spaces. The collection is defined by a distinct, fine rim that enhances the visual lightness of the otherwise solid and sturdy furniture. Its signature feature — large, supporting armrests — gives the collection its name. The pieces are designed for both semi-private and public spaces, suitable for both indoor and open-air settings. A small coffee table with a simple, timeless design offers exceptional strength and stability, making it virtually indestructible in public spaces. The unusually thin rim that pushes technological boundaries, combined with the strong and bold character of the collection, creates a striking contrast, reinforcing the unique identity of the Armstrong line.

MODEL

AR2020

DIMENSIONS

Height - 75 cm

Width - 143 cm

Depth - 56 cm

MATERIALS

- 100% recycled Polyethylen
+ Color Recycling Program
- UV stabilizer
- Anti-microbial

DESIGNER

- Studio Rygalik

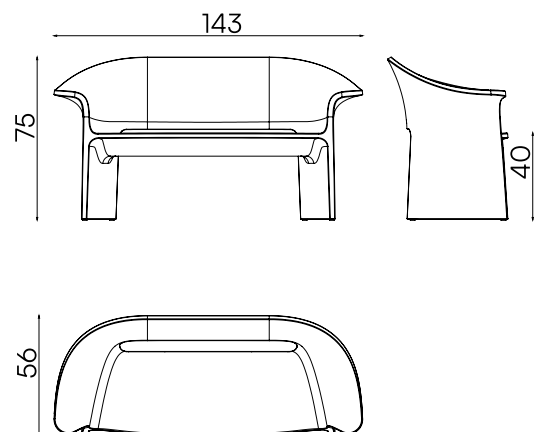

AVAILABLE COLOR VERSIONS



YellowBlack



BrownBlack



BlackBrown



YellowBeige



GreyBeige

COLOR RECYCLING PROGRAM

LOOPE redefines design - pioneering 100% circular technology to craft thoughtful, timeless, furniture solutions for a better life and a sustainable future.

Technology and material innovation are at the heart of LOOPE, offering endless possibilities. Plastic is often controversial, but our project proves that it can be used responsibly. We manufacture furniture from 100% pre-consumer recycled polyethylene, ready to be recycled repeatedly under controlled conditions. Sourced from fully valuable material left over from the production of planters, kayaks and other large-format elements made in our factory in Poland. This material returns to circulation in the form of durable furniture, instead of ending up as waste.

With full control over the recycling process, we ensure the polyethylene remains uncontaminated and, under controlled conditions, retains its key properties. This exceptional material is resistant to weather, scratches, breaks, and impacts. It's flexible, soft, yet incredibly durable extending the life of each piece.

ADDITIONAL INFORMATION

MAINTENANCE

- Products can be cleaned with warm water and a mild detergent.
- Avoid using harsh cleaning agents that may damage the surface.

TEMPERATURE RESISTANCE

- High-quality polyethylene retains its properties in temperatures ranging from -30°C to +60°C.

WARRANTY

- LOOPE is more than just furniture - it's a thoughtful system that redefines consumption.
- After five years, customers can return their furniture, and we'll transform it into a new product. This way, we extend its life and reduce plastic production. Warranty covers color and shape deformation.

DIGITAL FILE BASE

- PHOTOS
- VISUALIZATIONS
- 2D & 3D FILES